

MOBILE (QUEEN MARY) SHELVING UNITS

- ▶ 400 lbs. capacity per shelf
- ▶ Heavy-duty, solid adjustable shelves
- ▶ Smooth solid surface; easy to clean
- ▶ 1/8" Marine edge, contains spills
- ▶ All aluminum – WILL NOT RUST
- ▶ Easy "locking bushing" assembly
- ▶ Ships "knock down" UPS
- ▶ Heavy-duty 5" stem casters – 2 5" Swivel (CHV), 2 5" swivel locking (CHL)

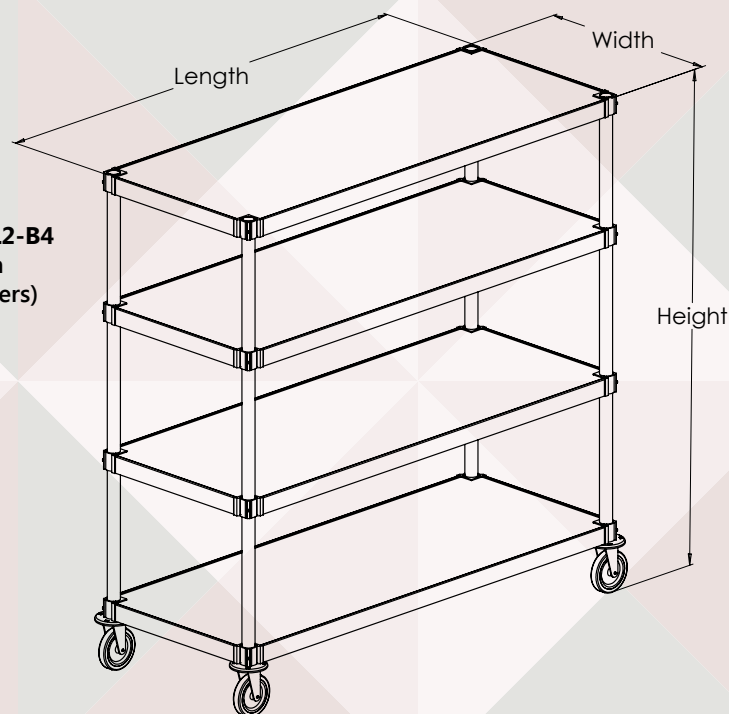

N244860-4-CHL2-B4
(shown with optional bumpers)



Mobile (Queen Mary) Shelving Units

Model Number	Size W x H x L
N204836-4-CHL2	20" x 54" x 36"
N204848-4-CHL2	20" x 54" x 48"
N204860-4-CHL2	20" x 54" x 60"
N206036-4-CHL2	20" x 66" x 36"
N206048-4-CHL2	20" x 66" x 48"
N206060-4-CHL2	20" x 66" x 60"
N244836-4-CHL2	24" x 54" x 36"
N244848-4-CHL2	24" x 54" x 48"
N244860-4-CHL2	24" x 54" x 60"
N246036-4-CHL2	24" x 66" x 36"
N246048-4-CHL2	24" x 66" x 48"
N246060-4-CHL2	24" x 66" x 60"

Options: CL, CHV, CHL, B – see page 82 for details



Prairie View Industries Food Service

PHONE 800.554.7267 | FAX 402.729.4058 | WEB www.pvifs.com