

## General

Please read this **BM-11-401 Mount** installation manual carefully in order to profit fully from its benefits. Take care that the mounts and load cells are applied within their specifications. Certainly during installation special attention should be paid to exceptional forces exceeding these specifications.

## Dimensions

Description	Dimension 5 – 200kg	Dimensions 250 – 500kg
Top Plate	75mm x 90mm	100mm x 120mm
Bottom Plate	130mm x 90mm	160mm x 120mm
Total Height	77mm	90mm

## Assembly

Before installing the mount into the application, the stay rod assembly should be removed. The mount should be assembled and set to the installation height at which the load cell is not loaded:

Capacity	Working Height	Installation Height	Mounting Torque Load Cell
5-50 kg	77 mm 3.03 inch	81 mm 3,19 inch	15 Nm 20.5 Lb ft
100-200 kg	77 mm 3.03 inch	81 mm 3,19 inch	25 Nm 34 Lb ft
250-500 kg	90 mm 3.54 inch	94 mm 3,70 inch	40 Nm 54 Lb ft

Table 1

Assemble the mount as follows:

- Assemble the mount (without the load cell) as shown in picture 1, taking care that the top and base plates are correctly aligned (vertically).
- The top plate (see drawing and Part List pos. 10) should be locked at installation height using the socket head counter sunk bolts (pos. 9) and the upper nut (pos. 7, see picture 1).

**Note:** the long bolts must not protrude above the top plate. This can cause weight on the long bolts and that will distort the measured value.

- Then the socket head counter sunk bolts (pos. 9) should be locked securely by turning the thin nut (pos. 6) downwards to the base plate (pos. 1).

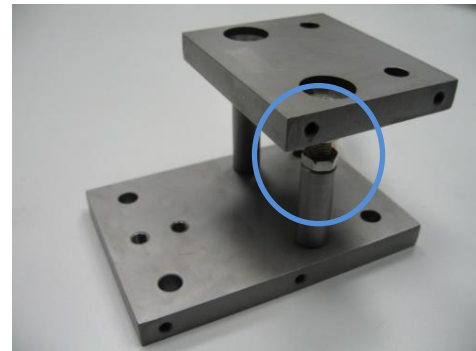

Picture 1

Then the mount is ready to install in the application of the customer.

## Installation

Important to know is to install multiple mounts in such a way that all bottom plates are at the same level and in the same horizontal plane. The same goes for the top plates. Always use shim plates to align mounts in the same horizontal plane and level. Always check that load cell and/or mount are not loaded with forces exceeding their specifications.

Install as follows:

- Locate the mount into the application and secure using the four lower and two upper fixing holes. Two hexagon bolts (1 upper and 1 lower) should be used to secure the earth cable (shown in Part List drawing pos. 14-15)
- Coat both bearing load surface (pos. 13) (see picture 2) with 'high pressure'-grease and locate the rocker pin support. Insert the rocker pin with lower bearing (pos. 11) in the load cell (see picture 3) and slide the load cell into place, ensuring that the rocker pin (pos. 13) is properly located (see picture 4).
- Place the load cell in the mount by putting it between the bottom plate and top plate in a half turned position and put it upright ensuring that the rocker pin is properly located in the right position

**Warning:** For safety reasons, always use a tool to align the rocker pin if necessary during this process, don't ever use your hands.

- Secure the load cells with the bolts (See Table 2) (pos. 3). Make sure that the washers (pos. 3 & 4) are placed and that the correct torque (see Table 1) on the bolts is used (see picture 5).

Description:	Dimensions 5 – 200kg	Dimensions 250 – 500kg
Hexagon screws to fasten load cell	M8 x 45	M10 x 50
Socket head countersunk screws	M8 x 40	M8 x 40
Bolts to fasten the earth cable	M6 x 6	M6 x 6

Table 2



Picture 2



Picture 3



Picture 4



Picture 5

- Then rotate the upper nut (pos. 7) counter clockwise by 1/2 turn at a time until the full load is taken by the load cell. Gradually apply the load to the load cell. This is done by lowering the upper nut underneath the top plate one-by-one with small steps. This way no exceptional high forces are introduced to the mounts or the load cells.

**Warning:** For safety reasons, always use a tool to align the load pin if necessary during this process.

- Check the free movement of the mount and its installation height, whether the socket head counter sunk bolts are touching the application or not and the free movement of the top plate

If the installation height is correct, the bolts are not touching the application and the top plate is free to move, then the assembly is ready to be used in the installation.

## Technical Specifications BM-11-401 Mount

Capacity	5 – 200kg	250 – 500kg
Maximum vertical force (down)	10 kN	30 kN
Maximum vertical force (up)	5 kN	10 kN
Maximum horizontal force	5 kN	15 kN
Maximum horizontal movement	+1 / -1 mm	+1 / -1 mm

## Dimensions in mm

### Side View

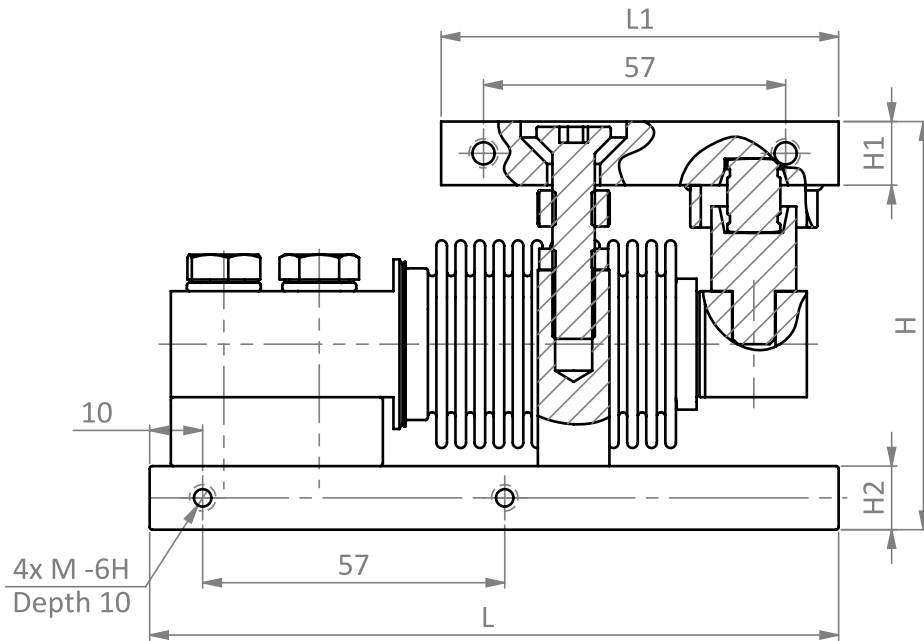

Fig. 2

### Top View

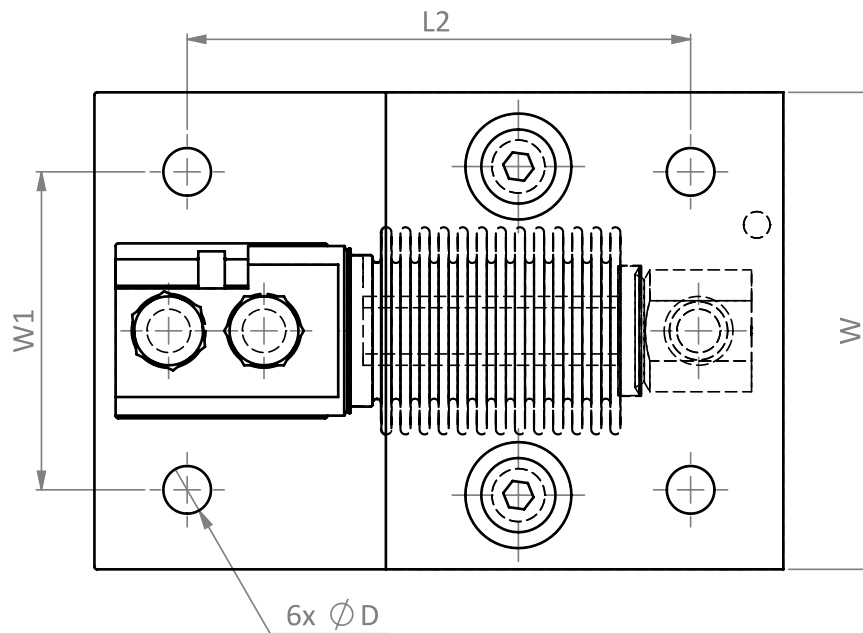

Fig. 3

Dimension \ Capacity	H	H1	H2	L	L1	L2	W	W1	ØD	M
5 – 200kg	77	12	12	130	75	95	90	60	9	M5
250 – 500kg	90	20	15	160	100	100	120	80	14	M5

Specifications and dimensions are subject to change without notice and do not constitute any liability whatsoever.

## Part List

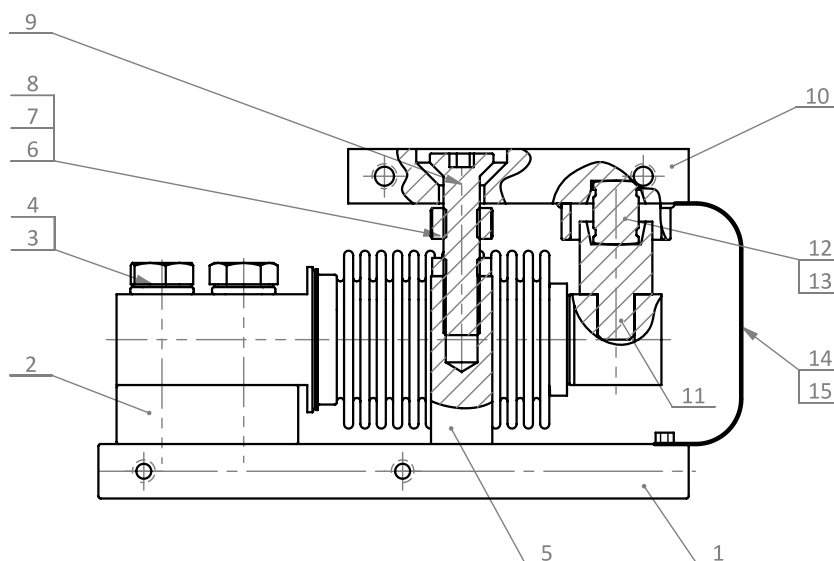

Fig. 4

Position	Description	Quantity
1	Base plate	1
2	Spacer plate	1
3	Hexagon bolt	2
4	Washer	2
5	Stub	2
6	Nut (Lower)	2
7	Nut (Upper)	2
8	Washer	2
9	Hexagon socket head counter sunk bolt	2
10	Top plate	1
11	Lower bearing	1
12	Rocker pin support	
13	Rocker pin	1
14	Earth cable	1
15	Hexagon bolt + washer	2

## Use

Routine maintenance includes the optical inspection of bolts, plates and force bearing parts, as well as the removal of dirt, dust and debris built up near or between the load cell and/or mount in order to let it move freely.

## Finally

A load cell will perform within specifications until the safe load limit or safe side load limit is passed. Beyond this point, even for a very short period of time, the load cell will be permanently damaged. The load cell may physically break at the ultimate load limit.

When not working properly remove load cell with care and attach a label with comments relating to the problem or mode of failure. Return also a copy of the Certificate of Calibration with the load cell if available.

Don't cut cable at the gland to facilitate removal - please - we cannot test load cells without cables!