



SWISS MADE
SWISS TECHNOLOGY

prepASH
THERMOGRAVIMETRIC ANALYSER



PRECISA DNA: ZERO COMPROMISE

Laboratory and industrial technicians are aware of the significance of the results they provide. That is why they are unwilling to accept any compromise in their field of work. This is precisely why leading specialists around the world place their trust in Precisa and have done for decades.

PRECISA DNA: SERIES 340

Over 40 years of experience made it possible to provide reliable weighing data during drying and ashing. The inbuilt analytical balance enables automatic endpoint detection and weight control during the whole analysis.

PRECISA DNA: SWISS PRECISION

Precisa products are prime examples of Swiss perfection and reliability. They are tried and tested in both demanding laboratory environments and industrial applications, and are subject to rigorous quality controls throughout the entire manufacturing process. Precisa invests continuously in developing new technologies and employs a highly qualified team. The result is a state-of-the-art range of precision instruments for the most exacting demands.



FULLY AUTOMATED

The equipment works completely autonomously once it is loaded and started. This offers the user a completely new time management option as the analysis can be run at different time periods which could not previously be used (e.g. at night).

By the permanent recording of the measurements during the entire process and the automatic storage of the final results, results are available at any time.

INTUITIVE TOUCH SCREEN CONTROL

prepASH features a high resolution colour touch screen (VGA 5.7") which is simple and easy to use thanks to the language-independent icons. The sample chamber is opened and closed automatically by touching the icon on the screen.

DRY WEIGHT AND ASH

One of the most important parameters in analytical testing of many materials and substances is the determination of dry weight and ash. This is often time-consuming and has a high error potential when performed in the classic way with drying/muffle oven and precision balance.

EFFICIENT DAILY ANALYSIS

prepASH with its easy operation is a fully automatic analysis system for thermo gravimetric determination of dry weight and ash. The prepASH intelligently unites the functions of a drying oven, muffle oven, analytical balance and evaluation unit into one system.

HEATING & CAPACITY

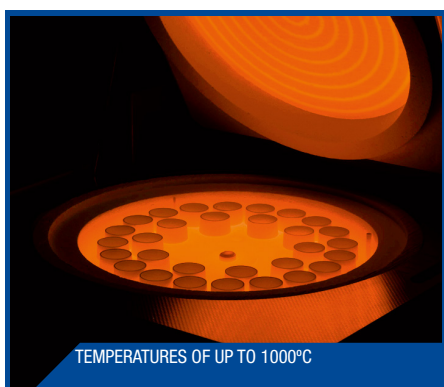

TEMPERATURES OF UP TO 1000°C



35ML PORCELAIN GLAZED CRUCIBLE

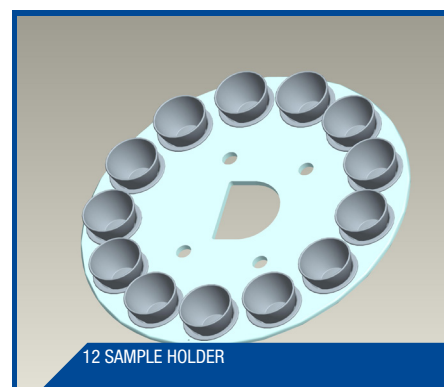

12 SAMPLE HOLDER



QUARTZ GLASS THERMAL PROTECTION



40ML PORCELAIN GLAZED CRUCIBLE

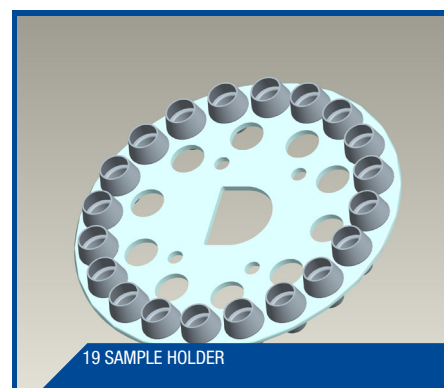

19 SAMPLE HOLDER

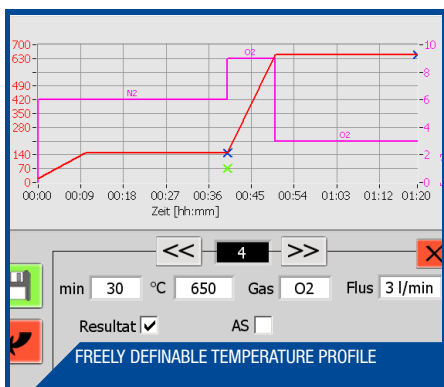

FREELY DEFINABLE TEMPERATURE PROFILE



50ML PORCELAIN GLAZED CRUCIBLE

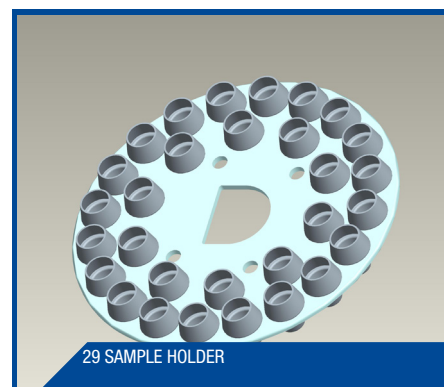

29 SAMPLE HOLDER

From 12 to 29 Samples in One Run

High efficiency through the simultaneous analysis of Moisture, Ash and Volatiles of up to 29 samples in one run. Optional sample plates are available on demand.

Analysis operating at temperatures of up to 1000°C

Powerful heating element ensures fast and homogenous temperature distribution within a wide temperature range of 50°C to 1000°C.

Quartz glass protection

The heating element is protected with quartz glass providing excellent thermal shock resistance.

Temperature Profile

The temperature profile is freely definable with ramping and holding temperatures enabling moisture, volatile and ashing with one single weighing. Temperatures can be set between 50°C to 1000°C. Combustion atmosphere can be varied by choosing the process gas (air, O₂, N₂).

Adapt to the needs of the sample

- Work with crucibles which fit best the application.
- Work with your own special crucibles in the adapters of the 12 sample plate.

BALANCE & WEIGHING

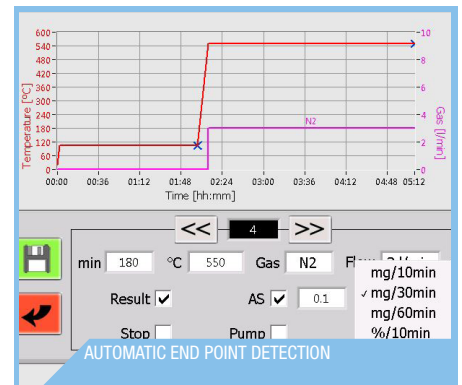
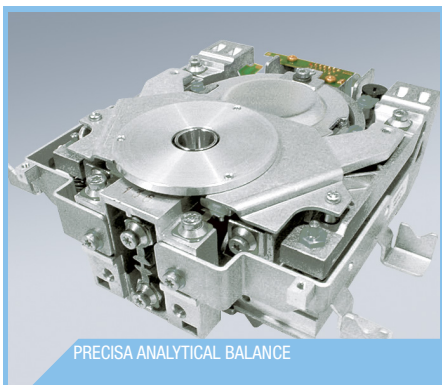

Ir.	Name	ID	T [g]	Sample [g]
R	Reference	-	30.5990	30.5990
1	S1	1	30.0657	5.3368

Z 5.3750

Act. pos.: 2
Next pos.: 3

S ✓

WEIGHING INTERFACE

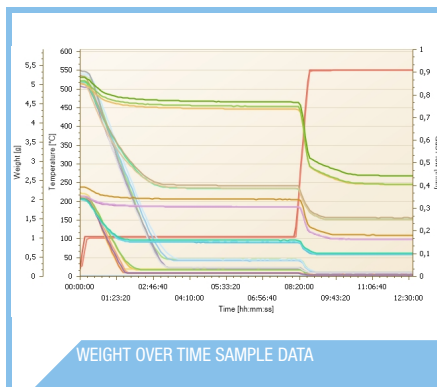

Precisa Analytical Balance

With built-in high performance, Precisa's analytical balance with its unique housing, provides direct weighing at 0.1 mg resolution, eliminating the need for an additional balance.

Continuous Control of the Analytical Cycle

Weighing curves are recorded over time for each individual test sample. This permits automatic end-point determination and control during the entirety of the drying and ashing process. No additional computer is needed.

Automatic End Point Detection

The analysis is finished when all samples have reached a stable weight. The auto-stop criteria can be chosen from 0.1-9.9 mg per 1 min, 30 min or 60 min. Alternatively the analysis can be stopped at a fixed time.

CONNECTIVITY & OUTPUT



Standalone Device

Standalone, but well connected. High-resolution graphics touch screen (colour, VGA 5.7") which is simple to use and features language-independent user guidance using icons. Process sequence with all parameters shown on the colour screen. No additional computer required.

Connectivity Options

Ethernet, 2 USB ports and RS232. Connect to/with: PC (ethernet or direct), Keyboards, Barcode reader, USB-Sticks, Printer.

Transfer Data

All measurement data is stored on the device and can be reproduced by means of USB stick or over the network on the PC and transferred into LIMS.

PC software prepDATA for extended data evaluation, online monitoring, statistic and report preparation.

QUALITY & CONTROL



201117SIV.log

Start Time: 11/17/2020 12:43:13 PM
 End Time: 11/18/2020 1:22:26 AM
 User prepASH: PRECISA1
 User:

Method: VEAS_Test_nov_20.log

Step	Temp 1 [°C]	Temp 2 [°C]	Gas	Gas Flow [l/min]	Time [min]	Auto Stop [1/min]	Manual Stop	Result
1	20	105			10			
2	105	105			480	2 mg/60		Loss [%]/Start (A)
3	105	550			30			
4	550	550			120			Residue [%]/Start (B)
5	550	550			120	0,5 mg/30		Residue [%]/Start (C)

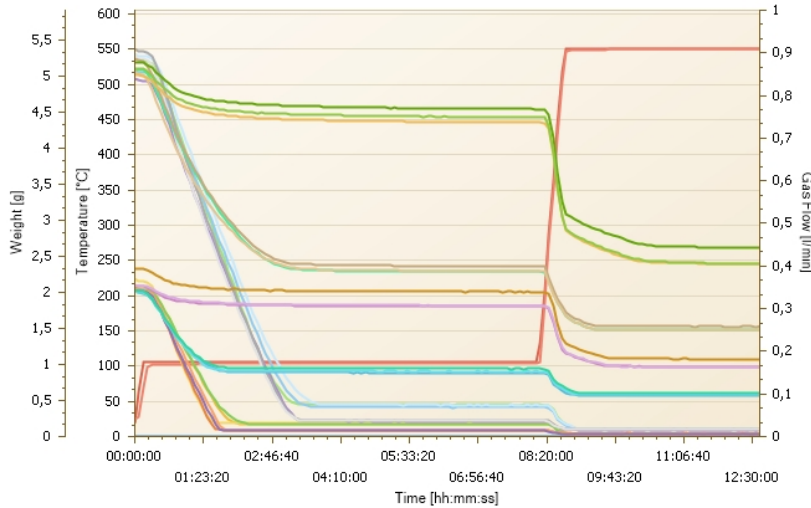

Result:

Group	Pos.	Sample	ID	Tare [g]	Weight [g]	A: Loss[%]/Start			B: Res[%]/Start			C: Res[%]/Start					
						Result	Weight [g]	Calc.	Time	Result	Weight [g]	Calc.	Time	Result	Weight [g]	Calc.	Time
1	1	Sample1 2g	-	13,7531	2,0567	A	(AS) 0,1767	91,409	03:14	B	0,0384	1,867	10:40	C	(AS) 0,0390	1,896	11:20
						A	(AS) 0,1842	91,607	02:49	B	0,0409	1,863	10:40	C	(AS) 0,0404	1,841	11:20
						A	(AS) 0,1746	91,582	03:20	B	0,0375	1,808	10:40	C	(AS) 0,0384	1,851	11:20
2	4	Sample1 5g	-	17,9643	5,2566	A	(AS) 0,4444	91,546	04:35	B	0,0988	1,880	10:40	C	(AS) 0,0984	1,872	11:20

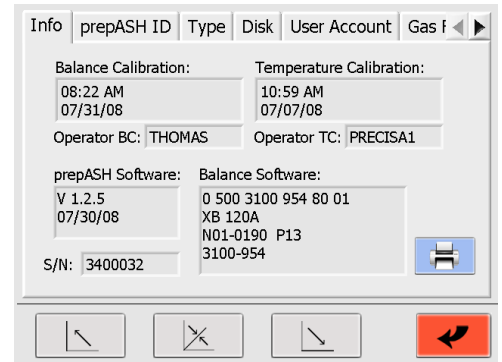
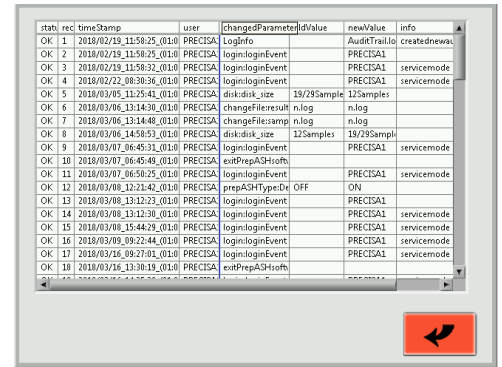

Quality Management Protocol

All 3 prepASH 340 Series models work autonomously as stand-alone-units and offer full control and documentation. They display the weight loss of each individual sample during the program steps and display these on the colour Touch Screen display.

Beyond that all models can be connected through Ethernet interface to the network and be remotely monitored by means of prepDATA software on the PC.

The results are calculated as losses or residuals in respect of weighing-in or pre-interval values (e.g. dry mass). The user may choose between %, ‰, g/kg, g.

- User identification with password at different access levels
- Hardware/Software and adjusting information; printed on each report
- Audit Trail

OPTIONS & SPECIAL APPLICATIONS



prepSTATION with Advanced Cooling

High Sample Throughput

prepSTATION with advanced cooling system improves workflow and manages high throughput testing.



Scrubber

Sulfated-Ash

A scrubber may be connected with sulfated ash application. Sulfuric acid fuming step can be done automatically in prepASH.

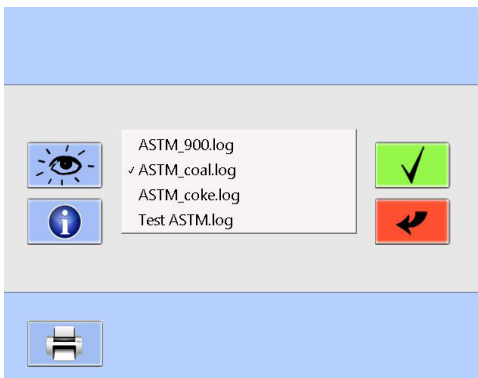

Coal/Coke Interface

Coal/Coke Applications

Determine moisture, volatiles, fixed coal and ash in one analysis. There is a predefined, calibrated method for the coal/coke in which you can easily adapt parameters. Work with our special crucibles with lids.

MODELS

Model	Capacity	Readability	Repeatability	Temperature Range	Crucibles	Response Time	Item No.
prepASH 229	120 g	0.1 mg / 0.01 ‰	1 g / 0.2 ‰ 10 g / 0.02 ‰	50 - 1 000°C	29 pcs. / 35 ml	4 s	340-9220-001
prepASH 219	120 g	0.1 mg / 0.01 ‰	1 g / 0.2 ‰ 10 g / 0.02 ‰	50 - 1 000°C	19 pcs. / 35 ml	4 s	340-9221-001
prepASH 212	120 g	0.1 mg / 0.01 ‰	1 g / 0.2 ‰ 10 g / 0.02 ‰	50 - 1 000°C	12 pcs. / 40 ml	4 s	340-9222-001

Options				Recommendations		
	prepASH 229	prepASH 219	prepASH 212	Standard Applications	Sulfuric Acid Applications	Volatile (Coal, Coke)
3 inputs gas flow control unit for air and 2 additional gases (N ₂ , O ₂)	340-8502	340-8502	340-8502	yes	yes	essential
prepSTATION includes: - prepSTATION unit - EP 120A analytical balance - Data cable for the connection between prepSTATION and balance	340-9010	340-9010	340-9010	yes	yes	no
Scrubber, Condensation-neutralization-absorption unit for e.g. determination of sulfated ash with sulfuric acid	340-9001	340-9001	340-9001	optional	essential	no
Scrubber, Condensation-Absorption-Connection-Set	340-9002	340-9002	340-9002	optional	essential	no
ECD Enhanced cooling device	340-8504	340-8504	340-8504	yes	yes	yes
ECD Enhanced cooling device, as retrofit kit	340-9004	340-9004	340-9004	yes	yes	yes

Accessories				Recommendations		
	prepASH 229	prepASH 219	prepASH 212	Standard Applications	Sulfuric Acid Applications	Volatile (Coal, Coke)
Sample plate for 29/19 crucibles, silicate ceramic SiC, for prepASH 229 and prepASH 219	standard (340-4065)	standard (340-4065)	–	standard 229/219	standard 229/219	standard 229/219
Crucible 35ml, porcelain glazed, set of 5 pieces APPROVED for applications with acid	standard	standard	340-8037	standard 229/219	standard 229/219	no
Crucible 26ml, Al ₂ O ₃ , for use with lid Al ₂ O ₃ , set of 5 pieces, use with sample plate 29/19 and crucible-lid 340-8033 NOT recommended for applications with acid	340-8032	340-8032	340-8032	yes	yes	standard 229/219
Crucible-lid, Al ₂ O ₃ , set of 5 pieces use with sample plate 29/19 and crucible 340-8032	340-8033	340-8033	340-8033	yes	yes	standard 229/219
Sample plate for 12 large crucibles, silicate ceramic SiC, for prepASH 229/219/212 use with adapter 340-8035	340-4072	340-4072	standard	standard 212	standard 212	no
Adapter for crucible, silicate ceramic SiC, set of 5 pieces use only with sample plate 12 and standard crucible 340-8034, 340-8038 or other crucible available from the market	340-8035	340-8035	standard	standard 212	standard 212	no
Crucible 40ml, porcelain glazed, SiC ASTM D 189-65, set of 5 pieces, use only with sample plate 12 and adapter 340-8035 APPROVED for applications with acid	340-8034	340-8034	standard	standard 212	standard 212	no
Crucible 50ml, porcelain glazed, set of 5 pieces use only with sample plate 12 and adapter 340-8035 NOT recommended for applications with acid	340-8038	340-8038	340-8038	yes	yes	no
Sample plate holder	340-8012	340-8012	340-8012	yes	recommended	yes
Crucible tongs	PN 3950-099	PN 3950-099	PN 3950-099	standard	standard	–
Crucible tongs for crucible with lids	340-7090	340-7090	340-7090	–	–	standard
Protection for Thermocouple	340-8516	340-8516	340-8516	optional	optional	optional

Additional Accessories & Applications

- Further accessories, see Special Products / Accessories

SPECIFICATIONS

Model	prepASH 229	prepASH 219	prepASH 212
Samples, Crucibles			
Samples	29	19	12
Sample plate for 19/29 samples	standard	standard	no
Crucibles 35 ml	35	25	no
Sample plate for 12 samples	option	option	standard
Adapter	option	option	15
Crucible 40 ml	option	option	15
Crucible 50 ml	option	option	option
Weighing system			
Weighing range	120g	120g	120g
Readability	0.0001 g	0.0001 g	0.0001 g
Minimum sample weight	0.1 g	0.1 g	0.1 g
Heating control system			
Temperature range	50°C - 1000°C	50°C - 1000°C	50°C - 1000°C
Temperature stability	+ / - 2 %	+ / - 2 %	+ / - 2 %
Process control system			
Maximum program steps	10	10	10
Maximum total analysis time	36 h	36 h	36 h
Auto stop	0.1 - 100 mg / 1 min, 30 min, 60 min	0.1 - 100 mg / 1 min, 30 min, 60 min	0.1 - 100 mg / 1 min, 30 min, 60 min
Atmosphere			
Oxygen, 0/3/6/9 l/min	option	option	option
Nitrogen, 0/3/6/9 l/min	option	option	option
Air, 0/3/6/9 l/min	option	option	option
Exhaust	yes	yes	yes
Absorption unit for sulfuric acid	option	option	option
Results			
Weight loss / Residual weight	%, ‰, g	%, ‰, g	%, ‰, g
Weight loss / Residual weight related to pre-interval	%, ‰, g	%, ‰, g	%, ‰, g
Repeatability	1 g / 0.02 %	1 g / 0.02 %	1 g / 0.02 %
Monitoring			
Remote on PC via Network	yes	yes	yes
Acoustic	yes	yes	yes
Operation			
Display	5.7" VGA colour	5.7" VGA colour	5.7" VGA colour
Keyboard	touch screen	touch screen	touch screen
Menu-controlled	yes	yes	yes
PC independent operation	yes	yes	yes
Sample list, preparation and evaluation on PC via network	yes	yes	yes
Sample preparation outside (with balance)	yes	yes	yes
Printout			
Graphic	yes	yes	yes
Table	yes	yes	yes
Method	yes	yes	yes
Memory capacity			
Methods	unlimited	unlimited	unlimited
Measured values	unlimited	unlimited	unlimited

SPECIFICATIONS

Model	prepASH 229	prepASH 219	prepASH 212
Data output, interfaces			
RS232 interface for external weighing in	with USB converter	with USB converter	with USB converter
USB for Printer	yes	yes	yes
USB for Barcode Scanner	yes	yes	yes
USB for Memory stick	yes	yes	yes
USB for external weighing in	yes	yes	yes
Ethernet for Printer	yes	yes	yes
Ethernet for PC-Data-evaluation	yes	yes	yes
Ethernet for PC-Remote-observation	yes	yes	yes
Ethernet for PC-Remote-support	yes	yes	yes
Calibration			
Balance	2 point	2 point	2 point
Temperature	2 point	2 point	2 point
Connection			
Mains voltage	230 VAC (+15/- 20%)	230 VAC (+15/- 20%)	230 VAC (+15/- 20%)
Frequency	50 to 60 Hz	50 to 60 Hz	50 to 60 Hz
Current input	25 A	25 A	25 A
Weight and dimensions			
Weight	99 kg	99 kg	99 kg
Dimensions (H) Height with cover opened	H (H) x W x D / 620 (980) x 590 x 870 mm	H (H) x W x D / 620 (980) x 590 x 870 mm	H (H) x W x D / 620 (980) x 590 x 870 mm

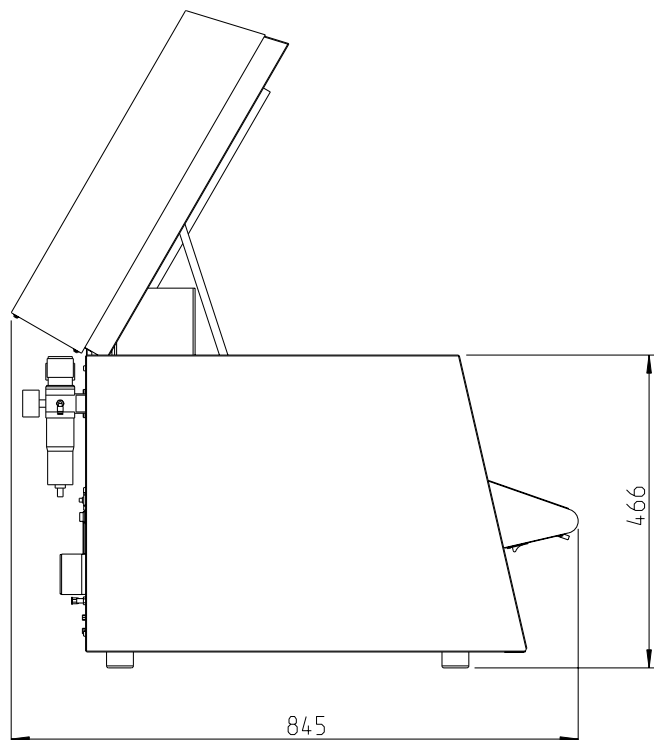
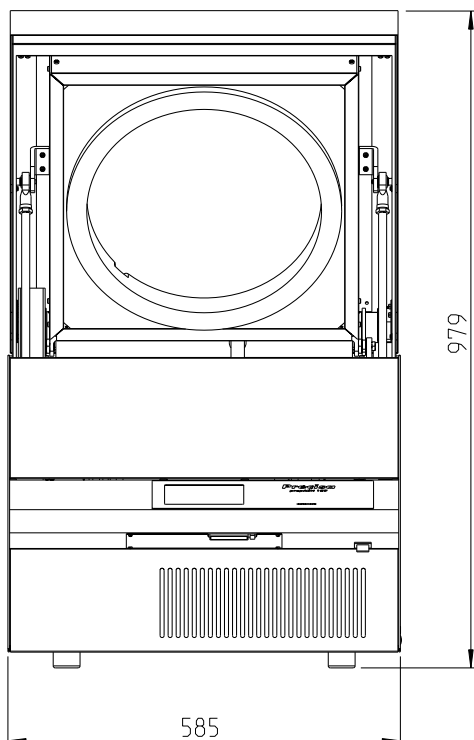

TECHCOMP GROUP

In addition to Precisa, Techcomp Europe comprises of the following companies:



Precisa Gravimetrics AG

Moosmattstrasse 32
8953 Dietikon, Switzerland
Tel. +41 44 744 28 28
Fax +41 44 744 28 38
Email: info@precisa.ch
www.precisa.com

ISO 9001:2015
BUREAU VERITAS
Certification

N° CH10355934

